



Development of IoT Based Monitoring System for CNG Cylinder Safety

A.O. Adedokun^{1*}, S. A. Adefegha¹

¹Federal University of Technology Akure, Nigeria

*Corresponding author email: aayoadedokun@gmail.com

KEYWORDS

IoT-based Monitoring
CNG Cylinder Safety
Gas Leakage
Explosion Prevention
Temperature Control

ABSTRACT

The Compressed Natural Gas (CNG) vehicles are becoming increasingly popular in Nigeria due to the sharp increase in the price of petrol and their environmental benefits. However, car owners who have recently converted their vehicles from petrol to CNG are increasingly concerned due to numerous reports of cylinder explosions across the nation. These explosions are primarily caused by high temperatures, excessive humidity, and gas leaks, posing significant safety risks. As a result, addressing these safety concerns has become an urgent priority. This research presents a smart IoT-based monitoring system designed to enhance the safety of CNG vehicles by continuously monitoring critical parameters such as cylinder temperature, car boot temperature, humidity, and gas leakage. The system utilizes real-time data collection and alert mechanisms to detect hazardous conditions early, enabling timely interventions and preventing potential explosions. The hardware includes an ESP8266 microcontroller, an MQ-4 gas sensor for detecting CNG leaks, DHT11 and DHT22 sensors for monitoring temperature and humidity of the car boot and the cylinder respectively. These components are integrated with a mobile app that delivers real-time monitoring and alerts, enhancing overall safety. By combining sensors with wireless communication, this IoT-enabled solution offers an effective and scalable approach to addressing CNG-related safety hazards, improving user safety while boosting public confidence in CNG technology.

Received 23 July 2025; Revised 10 December 2025; Accepted 31 March 2026; Published 01 April 2026.

1.0 INTRODUCTION

Compressed Natural Gas (CNG) is widely recognized as an eco-friendly and cost-effective alternative to traditional fuels, with its adoption in the automotive industry growing rapidly due to the need to reduce carbon emissions and combat climate change [1]. Despite these environmental benefits, CNG usage presents significant safety challenges, particularly in the storage and handling of CNG cylinders in vehicles [2]. High temperatures, excessive humidity, and gas leaks are among the primary causes of CNG cylinder explosions, posing severe risks to vehicle occupants and surrounding environments [3].

In Nigeria, several incidents of CNG cylinder explosions have been reported, often triggered by undetected gas leaks and overheating due to high ambient temperatures [4]. These incidents underscore the urgent need for more advanced safety monitoring mechanisms to detect and prevent hazardous conditions before they escalate. Traditional safety measures are reactive and often inadequate, providing limited real-time insights into the condition of CNG cylinders and surrounding environmental factors.

In addition to this, the Standard Organization of Nigeria (SON) has emphasized the importance of differentiating between Liquefied Petroleum Gas (LPG) and CNG cylinders. [5] clarified that the two types of cylinders are designed for different pressure levels and applications. CNG cylinders are seamless and can withstand much higher pressures, up to 300 bar, compared to LPG cylinders, which are built for lower-pressure environments. This distinction is critical for ensuring the correct application and monitoring of safety standards specific to CNG cylinders.

This research aims to address these safety challenges by designing a smart IoT-based monitoring system that provides real-time monitoring of CNG cylinder temperature, car boot temperature, humidity, and gas leakage.

The system is designed to detect unsafe conditions early, enabling timely interventions to prevent explosions and other potential accidents. It incorporates key hardware components such as the ESP8266 microcontroller for processing, the MQ-4 gas sensor to detect CNG leaks, and the DHT11 and DHT22 sensors for monitoring temperature and humidity of the car boot and the cylinder respectively. Since methane, which makes up 80 to 90% of CNG, is naturally odorless, ethyl mercaptan is added as an odorant for leak detection [6]. However, individuals with anosmia, or a weak sense of smell, may not detect a CNG leak immediately, increasing the risk of an explosion that could affect both the vehicle and the surrounding area. By integrating these sensors and IoT technology, this solution not only enhances vehicle safety but also contributes to the broader goal of promoting the adoption of clean energy technologies in a safer and more reliable manner.

This system offers a proactive approach to CNG safety, combining technological innovation with practical implementation to safeguard lives and property. This paper explores the development, implementation, and potential impact of the IoT-based monitoring system, emphasizing its role in preventing CNG cylinder explosions and promoting a safer transition to sustainable energy solutions.

2.0 METHODOLOGY

2.1 Materials and equipment

The Figure 1 shows the block diagram of the proposed system. The system's hardware consists of seven primary components: ESP8266 Microcontroller, power supply unit, MQ4 sensor, DHT 22, DHT 11, buzzer and fan unit.

The system's hardware consists of an ESP8266 microcontroller, which serves as the central controller for the device, coordinating data from the sensors and executing actions based on predefined conditions. The MQ-4 gas sensor is employed to detect gas leaks from the CNG cylinder in the vehicle's boot, providing early warnings if any leakage is detected. Additionally, two types of temperature and humidity sensors are used to monitor critical environmental parameters. The DHT11 sensor monitors the temperature and humidity inside the car boot, where the CNG cylinder is stored, with a maximum temperature range of 50°C. This sensor ensures that the ambient conditions remain within safe limits to prevent any indirect risks of explosion. On the other hand, the DHT22 sensor is dedicated to monitoring the temperature of the CNG cylinder itself, capable of measuring temperatures up to 80°C, ensuring the cylinder does not exceed dangerous levels.

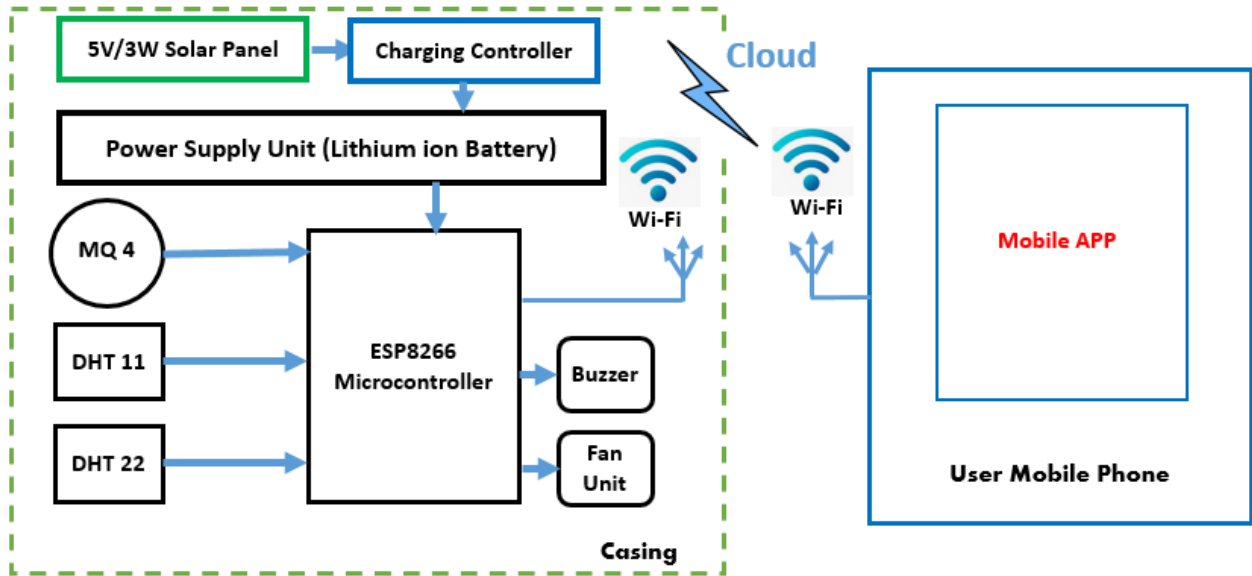

Figure 1: Block Diagram

As part of the safety mechanism, if the temperature of the CNG cylinder or the surrounding environment rises above the preset safety thresholds, the system automatically activates. A buzzer is triggered to alert the driver or vehicle occupants of the unsafe condition, and simultaneously, a fan is turned on to initiate a cooling process. This cooling mechanism helps reduce the temperature back to safe levels, thereby preventing potential hazards such as explosions. Once the temperature stabilizes within safe limits, the system automatically shuts down the cooling fan and deactivates the buzzer. This real-time monitoring and active intervention ensure that any potential safety threats from high temperature or gas leaks are addressed promptly, enhancing the overall safety of the CNG-powered vehicle.

2.1.1 ESP8266 Microcontroller

The ESP8266, a Wi-Fi microchip developed by Espressif Systems, is widely used in Internet of Things (IoT) applications due to its affordability, compact size, and versatility [7]. Although it has been succeeded by the ESP32, it remains popular among IoT developers. The ESP8266 module connects microcontrollers to 2.4 GHz Wi-Fi using the IEEE 802.11 bgn standard and can function as either a standalone microcontroller or provide Wi-Fi connectivity to external host MCUs through ESP-AT firmware. It includes a full TCP/IP stack, GPIO control, and data processing capabilities [8].



Figure 2: ESP8266 Microcontroller

As shown in Figure 2, the key specifications of the ESP8266 include a 32-bit Xtensa LX106 core clocked between 80-160 MHz, 160 KB of RAM, external QSPI flash ranging from 512 KB to 4 MB, 16 GPIO pins, and support for several interfaces like SPI, I2C, UART, and I2S. The module can handle networking, data processing from sensors, peer-to-peer communication, and even run as a web server. Applications include smart security devices, smart energy systems, industrial controllers, and medical monitoring devices [9]. The ESP8266 is available in three formats: the basic chip, surface-mountable modules, and development boards. Modules are typically FCC-approved and shielded, making them ideal for device manufacturers. Development boards, such as those by Espressif, WeMos, and Adafruit, allow developers to prototype IoT devices efficiently. The versatility of the ESP8266 continues to drive its widespread adoption across numerous IoT applications [10].

In this research, the ESP8266 functions as the central microcontroller responsible for enabling Wi-Fi connectivity in the IoT system. It connects various sensors, such as the MQ4 gas sensor and DHT11/DHT22 temperature and humidity sensors, and facilitates real-time data transmission to a cloud platform, Blynk, for monitoring CNG cylinder temperature, car boot conditions, and gas leakage. The ESP8266 processes sensor data and triggers safety actions like activating a buzzer or cooling fan when temperature thresholds are exceeded, ensuring timely alerts and preventive measures to avoid potential hazards in compressed natural gas (CNG) systems.

2.1.2 MQ 4 Gas Sensor

In this research, the MQ-4 gas sensor plays a critical role in detecting the presence of methane (CH_4), the primary component of compressed natural gas (CNG), which constitutes 80-90% of CNG. The sensor is installed in the car's boot where the CNG cylinder is located to monitor for any gas leaks that may occur. Methane is odorless and highly flammable, so detecting leaks is crucial for preventing potential explosions [11]. The MQ-4 sensor shown in Figure 3 is specifically designed for methane detection, making it ideal for this research, which focuses on creating a safety system to monitor CNG cylinder conditions and alert users to gas leaks before they become hazardous.



Figure 3: MQ-4 Sensor

The MQ-4 sensor uses a tin dioxide (SnO_2) semiconductor as its sensing material [12]. In the presence of methane or other combustible gases, the sensor's conductivity increases, allowing it to detect the concentration of methane in the environment. The sensor provides analog outputs that are read by the ESP8266 microcontroller, which then processes the data and triggers alarms or cooling mechanisms when dangerous levels are detected. The MQ sensor family includes a wide range of gas sensors, each designed to detect different gases. The table 1 compares the MQ-4 sensor with other commonly used MQ sensors:

Table 1: Comparison of MQ-4 with Other MQ Series Gas Sensors

Sensor	Gas Detected	Detection Range	Target Gases	Sensitivity	Operating Voltage	Heating Power Consumption
MQ-4	Methane (CH ₄)	200 - 10000 ppm	Methane, Natural Gas	High	5V	~0.75W
MQ-2	Smoke, LPG, Propane	300 - 10000 ppm	Smoke, Butane, Methane	Moderate	5V	~0.6W
MQ-3	Alcohol, Benzine	25 - 500 ppm	Ethanol, Benzine, Smoke	Moderate	5V	~0.5W
MQ-5	LPG, Natural Gas	200 - 10000 ppm	Methane, Propane, Butane	Moderate	5V	~0.75W
MQ-7	Carbon Monoxide (CO)	20 - 2000 ppm	Carbon Monoxide, Methane	High	5V	~0.5W
MQ-9	Carbon Monoxide, LPG	10 - 10000 ppm	CO, Methane, LPG	High	5v	~0.75W

The MQ-4 sensor was chosen for this research primarily due to its high sensitivity and specificity to methane, which makes up the majority of CNG. Other MQ sensors, such as the MQ-2 and MQ-5, can detect methane, but they also detect a range of other gases, such as propane and butane, which may lead to false alarms in this specific application. The MQ-4, on the other hand, is optimized for methane detection, providing more accurate and reliable readings in environments where methane leaks pose the highest risk. Also, the MQ-4 sensor has a wide detection range (200-10,000 ppm), which is appropriate for detecting varying levels of methane concentration, from small leaks to more dangerous levels. Its high sensitivity ensures that even minute traces of methane can be detected, which is crucial for early leak detection and accident prevention.

Moreover, the MQ-4's low power consumption and compatibility with the ESP8266 microcontroller make it a suitable choice for IoT-based systems, where power efficiency and real-time data processing are essential [13]. Since the ESP8266 can read the analog output from the MQ-4 and send real-time data to a cloud platform like Blynk, users can receive timely alerts and take preventive measures to avoid catastrophic events like explosions due to gas leaks. The sensor's ability to accurately detect methane, combined with its compatibility with IoT technologies, makes it the best choice for this research focused on ensuring safety in CNG-based systems. It offers a reliable and efficient solution for monitoring gas leaks, enhancing overall safety in vehicles using CNG.

2.1.3 DHT 11 and DHT 22: Temperature and Humidity Sensors

The DHT11 and DHT22 are popular sensors used for measuring temperature and humidity. Both are highly utilized in Internet of Things (IoT) applications and offer reliable performance for monitoring environmental conditions [11]. In this research, these sensors play crucial roles in

ensuring the safety of compressed natural gas (CNG) cylinders in vehicles, particularly in monitoring temperature and humidity within the car boot and the CNG cylinder itself. Their usage helps detect abnormal conditions that could lead to accidents, such as gas explosions caused by high temperatures or humidity levels.

The Figure 4 shows DHT11, a basic, low-cost digital sensor for measuring temperature and humidity. It uses a capacitive humidity sensor and a thermistor to measure the surrounding air. It then converts the data into digital signals for easy interfacing with a microcontroller like the ESP8266. The DHT11 offers a temperature range of 0°C to 50°C, with an accuracy of $\pm 2^\circ\text{C}$, and a humidity range of 20% to 90%, with an accuracy of $\pm 5\%$ [14].

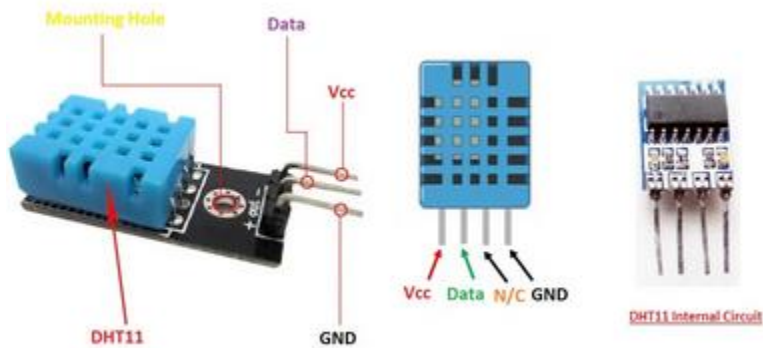

Figure 3: DHT11 Temperature and Humidity Sensor

One of the advantages of the DHT11 is its low cost and simplicity [15]. However, it has some limitations in terms of its relatively lower accuracy and smaller temperature range compared to more advanced sensors. This makes the DHT11 ideal for applications where precision is not the top priority but where basic environmental monitoring is required, such as monitoring the car boot temperature and humidity in this research. The maximum temperature range of the DHT11 (50°C) fits well within the safety requirements for the car boot.

In the same light Figure 4 shows the DHT22 sensor which is also known as the AM2302, is an upgraded version of the DHT11 with improved accuracy and a wider measurement range. It measures temperature from -40°C to 80°C with an accuracy of $\pm 0.5^\circ\text{C}$ and humidity from 0% to 100% with an accuracy of $\pm 2\%$ [16]. Like the DHT11, it uses a capacitive humidity sensor and a thermistor but delivers better performance overall.

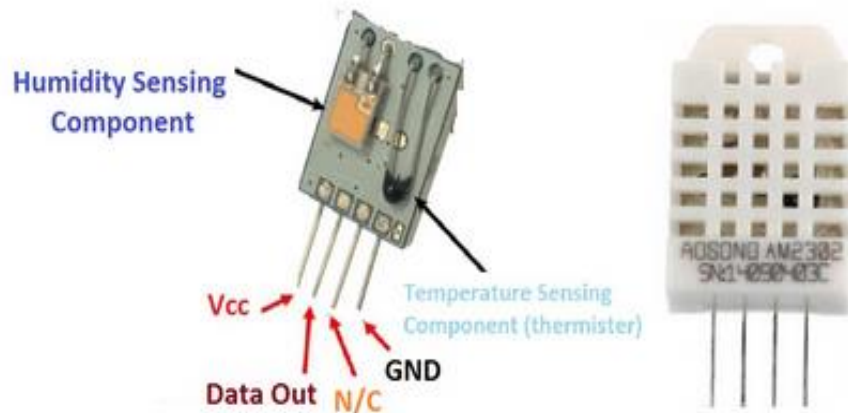

Figure 4: DHT 22 Temperature and Humidity Sensor

Due to its superior accuracy and wider range, the DHT22 is more suitable for critical applications where precision is necessary [17]. In this research, the DHT22 is used to monitor the

temperature of the CNG cylinder, where maintaining an accurate reading is essential for preventing dangerous conditions. The cylinder's temperature can rise above 50°C, which exceeds the DHT11's limit, making the DHT22 the more appropriate choice [18]. Table 2 shows the compares the two sensors.

Table 2: Comparison of DHT11 and DHT22 Sensors

Feature	DHT11	DHT22
Temperature Range	0°C to 50°C	-40°C to 80°C
Temperature Accuracy	±2°C	±0.5°C
Humidity Range	20% to 90%	0% to 100%
Humidity Accuracy	±5%	±2%
Sampling Rate	1 reading per second	0.5 readings per second
Cost	Low	Moderate
Response Time	Slower (1-2 seconds)	Faster (0.5-2 seconds)

In this research, the DHT11 is tasked with monitoring the car boot temperature and humidity since it provides adequate accuracy for non-critical areas and is cost-effective. The DHT11's maximum temperature range of 50°C is suitable for this task, as the boot is not expected to exceed this threshold under normal conditions [19].

The DHT22, on the other hand, is used for monitoring the CNG cylinder's temperature, which can potentially rise to dangerous levels above 50°C [20]. Its higher temperature range and better accuracy make it the optimal sensor for this critical application, where precise readings are needed to trigger safety mechanisms, such as cooling systems or alarms [21].

Both the DHT11 and DHT22 are integral to this research's safety monitoring system. The choice of these sensors is based on their respective accuracy, range, and cost-efficiency, aligning with the research's goal to prevent CNG-related accidents through effective environmental monitoring.

2.2 Proposed Device Circuit Design and Simulation

In this research project, the key components of the system include an ESP8266, DHT11 or DHT22 sensors, MQ4 gas sensor, and a buzzer. The ESP8266 acts as the microcontroller and Wi-Fi module, connecting to a Blynk cloud platform for data monitoring and alerts. The DHT sensors monitor temperature and humidity, while the MQ4 gas sensor detects methane leaks. The buzzer is used as an alert system when dangerous conditions are detected.

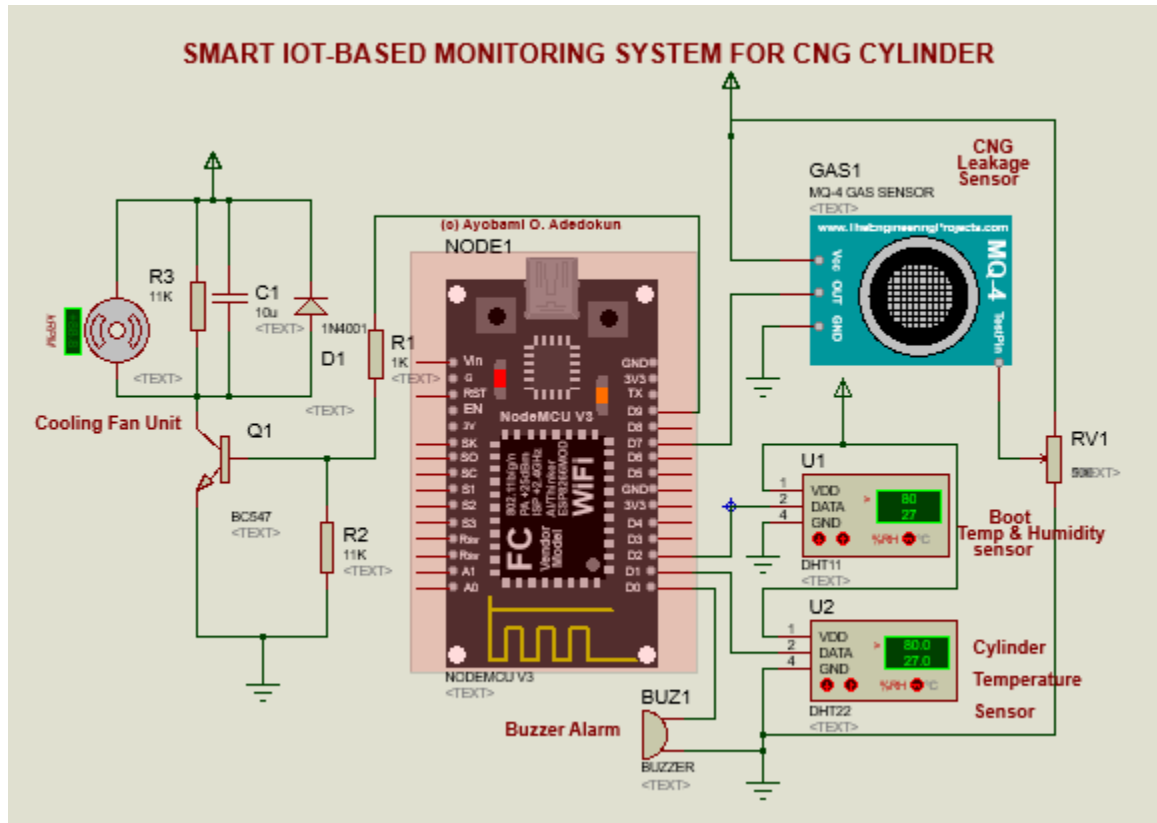

Figure 5: Circuit Simulation Diagram

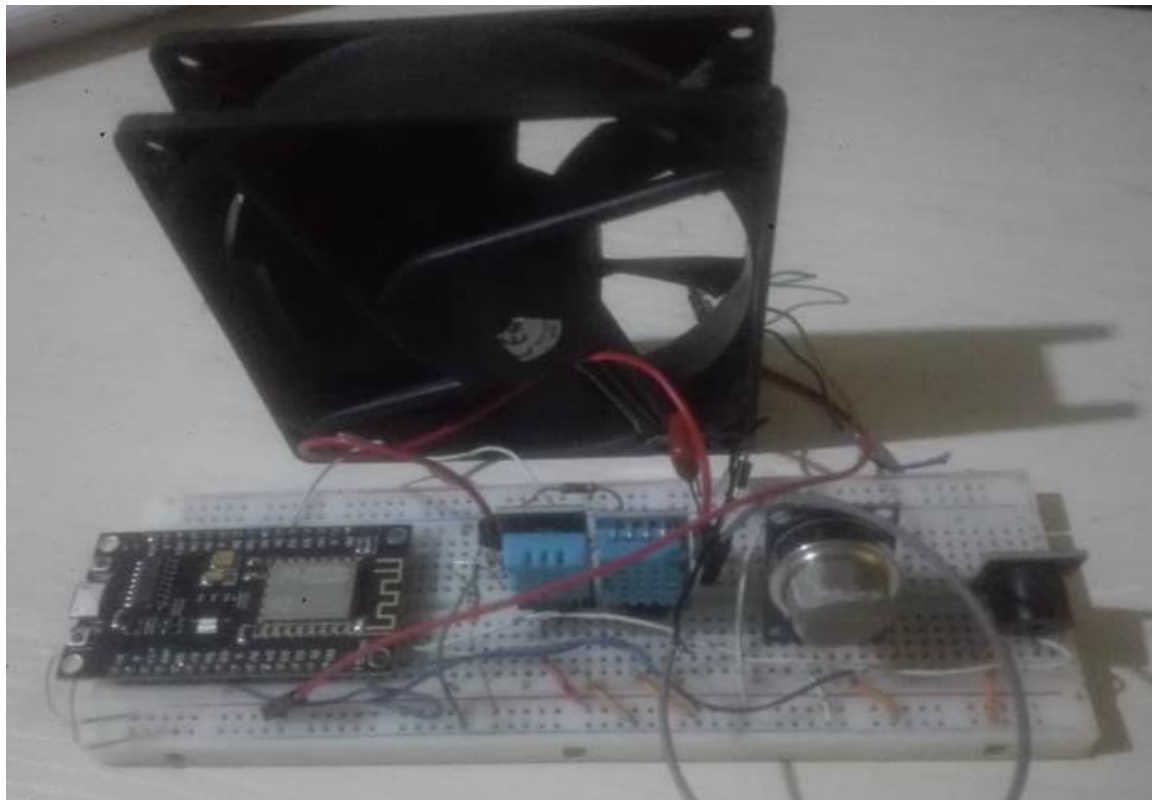

Figure 6: Pre-Testing Breadboard Circuit Arrangement

As shown in the Figure 5, the circuit for this IoT project is designed around the ESP8266 microcontroller, serving as the central hub for gathering environmental data from sensors and controlling output devices like a fan and a buzzer. The primary components involved in this system include the DHT11 and DHT22 temperature and humidity sensors, the MQ-4 gas sensor, a buzzer for alarms, and a fan unit driven by a BC547 transistor circuit. These components work together to monitor critical parameters like temperature, humidity, and gas leakage in an environment (boot), with the data transmitted to the Blynk cloud platform for remote monitoring and control.

The DHT11 sensor is used to monitor the temperature and humidity inside the vehicle's boot. It operates by detecting changes in air temperature and humidity and sending the corresponding data to the microcontroller for processing. In this circuit, the data pin of the DHT11 is connected to digital pin D2 of the ESP8266 microcontroller. The sensor uses a single-wire communication protocol to transmit data to the ESP8266. In practice, when the DHT11 detects changes in temperature or humidity, it sends signals through its data pin to the ESP8266, which reads these values and processes them to determine whether they exceed the predefined safe limits. The sensor also requires a power connection of 3.3V, which is provided by the ESP8266, and a ground connection to complete the circuit. The DHT11 has a temperature range of up to 50°C, making it suitable for monitoring the relatively moderate environmental conditions in the car's boot.

The DHT22 sensor, which has a broader temperature range compared to the DHT11, is used to monitor the temperature of the CNG cylinder. Its ability to measure temperatures up to 80°C makes it ideal for this application, as the cylinder can potentially reach higher temperatures under certain conditions. The data pin of the DHT22 sensor is connected to digital pin D1 of the ESP8266 microcontroller, similar to the DHT11, using a single-wire communication protocol. Like the DHT11, the DHT22 also requires a 3.3V power supply and a ground connection. When the DHT22 sensor detects that the temperature of the gas cylinder is approaching or exceeding safe levels, it sends data to the ESP8266, which then triggers the appropriate actions, such as activating the fan to cool the cylinder or sounding an alarm.

The MQ-4 gas sensor is responsible for detecting the presence of natural gas (methane) leaks in the car's boot. This sensor's data pin is connected to digital pin D7 of the ESP8266. The MQ-4 sensor outputs an analog signal that corresponds to the concentration of methane gas in the environment. The ESP8266 can process this signal to determine whether the gas concentration exceeds safety thresholds. The MQ-4 sensor requires both a power supply (3.3V or 5V) and ground to function. In this project, when the MQ-4 detects gas leakage, the ESP8266 interprets the data and activates the appropriate safety measures, such as sounding the buzzer to alert the user or turning on the fan to disperse the gas.

The buzzer in this system acts as an alert mechanism, warning users of dangerous conditions such as high temperature, humidity, or gas leakage. The buzzer is directly connected to digital pin D0 of the ESP8266. When any of the sensors (DHT11, DHT22, or MQ-4) detect an abnormal condition, the ESP8266 sends a signal to D0, causing the buzzer to sound. The buzzer requires a power supply and ground, which are provided by the ESP8266. This simple yet effective alarm system ensures that users are immediately informed of potentially hazardous situations inside the vehicle.

The fan unit in this project is designed to help cool the environment or disperse gas in case of a leak. The fan is controlled by a transistor driver circuit built around the BC547 NPN transistor. The base of the transistor is connected to digital pin D9 of the ESP8266 through a 1kΩ resistor. The collector of the transistor is connected to the fan's power supply, while the emitter is connected to ground. The purpose of using a transistor here is to act as a switch. When the ESP8266 sends a signal to pin D9, it turns on the transistor, allowing current to flow from the power supply to the fan, thereby activating it. The 1kΩ resistor serves to limit the base current to a safe level, ensuring that the transistor operates correctly without being damaged. The fan helps to maintain a safe environment by cooling down the CNG cylinder or dispersing any accumulated gas.

The data collected from the DHT11, DHT22, and MQ-4 sensors is transmitted to the Blynk cloud platform, allowing for real-time monitoring and control via a mobile app or web interface. The

ESP8266 connects to the internet through its built-in Wi-Fi capabilities, sending sensor data to the Blynk server. Users can access this data remotely, monitor environmental conditions, and receive alerts if any parameter exceeds safe levels. For example, if the temperature of the CNG cylinder rises above a predefined threshold, the Blynk app will notify the user, and the fan will be activated automatically. Similarly, gas leakage detection by the MQ-4 sensor will trigger an alert on the Blynk platform, and the buzzer will sound in response. This integration enhances the functionality of the system by providing users with remote access to crucial safety data and control mechanisms, ensuring timely interventions in case of emergencies.

The ESP8266 acts as the central controller, processing data from all the connected sensors and making decisions based on the collected information. The sensors continuously monitor the vehicle's boot environment, including temperature, humidity, and gas concentration. If any sensor detects abnormal conditions, the ESP8266 takes immediate action by activating the fan, sounding the buzzer, and sending alerts to the Blynk cloud platform. The combination of these hardware components ensures a robust system capable of preventing hazardous situations by taking automatic corrective actions and notifying users of potential dangers in real-time. The breadboard implementation of the circuit is illustrated in Figure 6.

3.0 RESULTS AND DISCUSSION

In this section, we present the results of the experiment, analyze the data obtained from the sensors, and discuss the system's performance in monitoring critical parameters such as temperature, humidity, and gas concentration within the vehicle's boot environment. This IoT-based system, leveraging the DHT11, DHT22, MQ-4 gas sensor, fan, and buzzer, was designed to prevent hazardous conditions such as overheating and gas leaks, particularly around a CNG cylinder.

3.1 Temperature and Humidity Monitoring

The DHT11 and DHT22 sensors were used to measure the temperature and humidity in the car's boot and the CNG cylinder area, respectively. The temperature and humidity were recorded over a 24-hour period, and the results are summarized in Table 3.

Table 3: Temperature and Humidity Monitoring

Time (hours)	DHT11 (Temp. °C)	DHT11 in (Humidity %)	DHT22 (Temp. °C)	DHT22 in (Humidity %)
0	24	45	26	38
2	25	47	28	41
4	26	50	29	42
6	27	52	30	44
8	29	55	31	46
10	31	57	32	48
12	33	60	34	49
14	34	62	35	50
16	36	64	37	51
18	35	63	36	50
20	34	62	35	48
22	32	60	34	46
24	30	58	33	45

As shown in Figure 7, the temperature in the car boot increased gradually from 24°C to a peak of 36°C at 16 hours, while the humidity ranged between 45% and 64%. This increase in temperature is consistent with ambient temperature variations during the day, highlighting the need for continuous monitoring to prevent overheating, especially in hot climates.

The DHT22 sensor recorded slightly higher temperatures around the CNG cylinder, with a peak temperature of 37°C. The humidity around the cylinder remained relatively stable, with a slight increase from 38% to 51%. The higher temperature around the cylinder indicates that it absorbs more heat due to the presence of gas, necessitating the use of a cooling mechanism (fan) to prevent overheating.

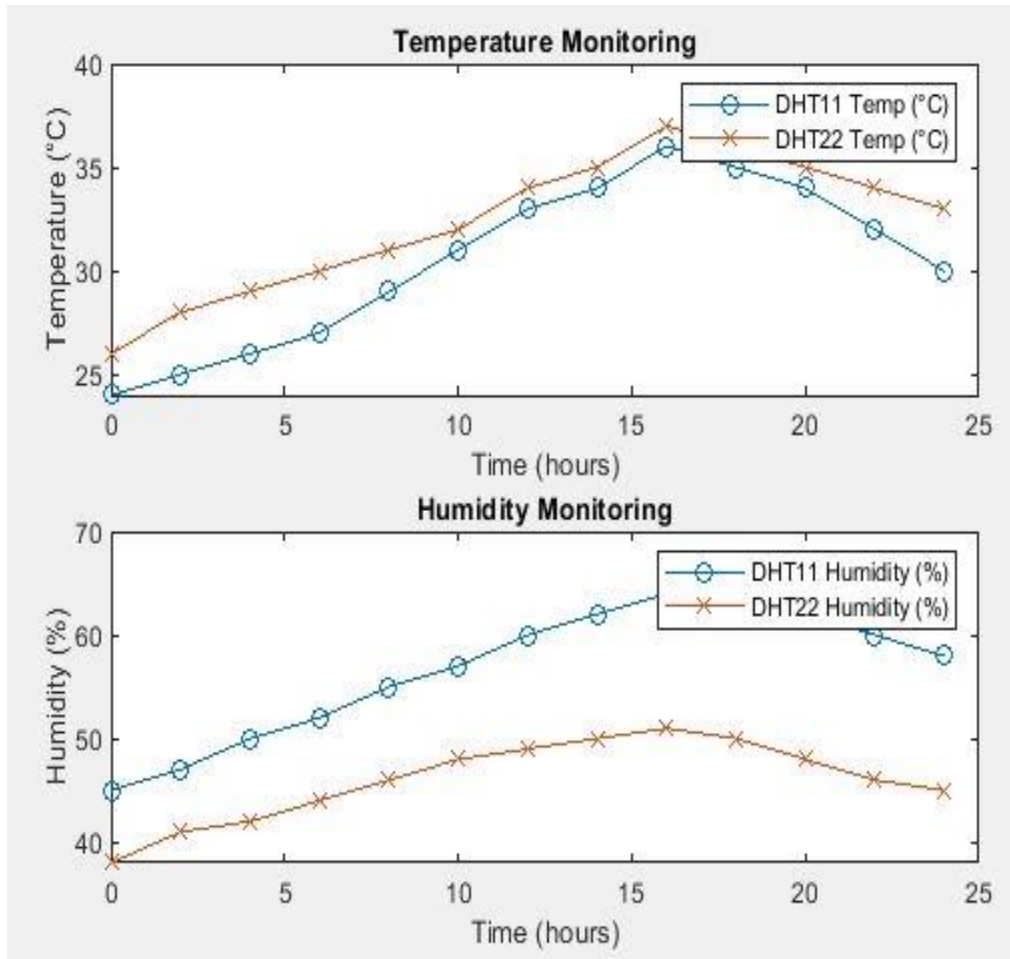

Figure 7: Temperature and Humidity Monitoring for DHT11 and DHT22

3.2 CNG Leakage Result

The MQ-4 sensor was used to detect methane gas concentrations in the car boot. Table 4 summarizes the gas sensor data during a simulated gas leakage.

Table 4: CNG (Methane Gas) Leakage Result

Time (hours)	MQ-4 Sensor Output (ppm)	Action Taken
0	200	None
2	230	None
4	250	None
6	270	Buzzer activated, Fan ON
8	290	Buzzer active, Fan ON
10	310	Buzzer active, Fan ON
12	320	Buzzer active, Fan ON
14	340	Buzzer active, Fan ON
16	360	Buzzer active, Fan ON

The MQ-4 sensor continuously monitored the methane concentration levels inside the car boot for the CNG cylinder and the gas concentration over time in the boot is shown in Figure 8. During the first 12 hours of operation, no gas leakage was detected, indicating that the cylinder was functioning optimally, and there was no risk of gas buildup in the vehicle's boot. The sensor consistently read low methane levels, confirming that the environment was safe. However, for experimental purposes, methane gas was manually introduced into the boot starting at the 12th hour to simulate a potential gas leak scenario. This intentional introduction of gas aimed to test the system's responsiveness and verify its ability to detect and manage hazardous conditions. Over the next four hours, the methane concentration steadily rose, eventually surpassing the 270-ppm safety threshold set in the system's programming. As the methane levels exceeded this threshold, the system's safety protocols were triggered. The buzzer was activated to alert nearby individuals of the potential danger, while the fan was automatically turned on to disperse the gas, lowering the concentration within the car boot and preventing a hazardous buildup. The fan's activation played a critical role in ventilating the enclosed space, helping to mitigate the risk of explosion due to high methane levels.

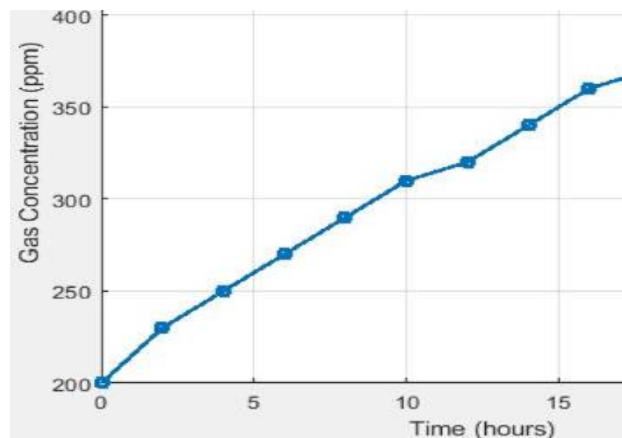

Figure 8: Gas Concentration overtime

By the 16th hour, the experiment was concluded, and the methane gas introduction was terminated. The sensor readings began to decline as the gas concentration dropped below the critical threshold, deactivating both the buzzer and the fan once the environment was deemed safe again. This deliberate test successfully demonstrated the system's real-time ability to detect abnormal methane levels, activate warning mechanisms, and manage potential hazards by dispersing dangerous gas concentrations. Such a system ensures proactive safety measures in vehicles equipped with CNG cylinders, thereby reducing the likelihood of catastrophic gas leaks.

4.0 CONCLUSIONS

This research successfully developed and tested an IoT-based safety monitoring system for vehicles equipped with CNG cylinders, addressing the critical need for preventing gas leakage and mitigating explosion risks. The integration of various sensors MQ-4 for gas detection, DHT11/DHT22 for temperature and humidity monitoring, and a fan and buzzer for alert and mitigation—demonstrates the system's capability to operate in real-time, providing immediate response to hazardous situations. The MQ-4 sensor efficiently monitored methane levels, and the system effectively responded when the concentration exceeded 270 ppm, triggering the fan and buzzer to prevent dangerous gas buildup. The manual introduction of methane for experimental purposes validated the system's sensitivity and responsiveness to gas leaks, as the sensor detected the increased concentration and initiated safety protocols. This real-time data collection and response were achieved through integration with the Blynk cloud platform, allowing for remote monitoring and control. The use of the DHT11/DHT22 sensors ensured that temperature and humidity conditions were also monitored, as elevated temperatures could increase the risk of gas leaks or accidents. The fan unit, controlled by a BC547 transistor circuit, functioned seamlessly in conjunction with the gas sensor, dispersing gas as needed.

Overall, the system provides a cost-effective, scalable solution for real-time safety monitoring in vehicles using CNG. This research highlights the importance of integrating IoT technologies for proactive hazard prevention and the effectiveness of cloud-based platforms like Blynk in enabling remote data access and control. Future iterations can focus on improving the system's scalability, integrating GPS tracking, and refining sensor calibration for even greater sensitivity to a broader range of hazardous gases. The results demonstrate the viability of using this solution to enhance safety in environments prone to gas leaks.

Authors Contribution

The authors contributed to the study's conception and design. Hardware design and simulation with analysis were performed by AO and CNG analysis for sensor calibration and validation were performed by SA. All authors read and approved the final manuscript.

Conflict of Interest

The authors declare that they have no known competing financial interests or personal relationships that could have appeared to influence the work reported in this paper.

Acknowledgements

Not Applicable.

5.0 REFERENCES

- [1] S. Sengupta and A. Sen, "Contending global warming by popularising environment-friendly-fuel compressed natural gas (CNG)," in *Making India Disaster Resilient: Challenges and Future Perspectives*, Cham, Switzerland: Springer International Publishing, 2024, pp. 71-85.
- [2] M. I. Khan, T. Yasmin, and A. Shakoor, "Technical overview of compressed natural gas (CNG) as a transportation fuel," *Renewable and Sustainable Energy Reviews*, vol. 51, pp. 785-797, 2015.
- [3] Z. Li and Y. Luo, "Comparisons of hazard distances and accident durations between hydrogen vehicles and CNG vehicles," *International Journal of Hydrogen Energy*, vol. 44, no. 17, pp. 8954-8959, 2019.
- [4] "Concern over CNG explosions as FG begins probe," *Punch*, Oct. 20, 2023. [Online]. Available: <https://punchng.com/concern-over-cng-explosions-as-fg-begins-probe/>. [Accessed: Oct. 21, 2024].
- [5] F. Okpale, "SON blames substandard CNG cylinder for vehicle explosion at Benin City filling station," *BusinessDay*, Oct. 20, 2024. [Online]. Available: <https://businessday.ng/news/article/son-blames-substandard-cng-cylinder-for-vehicle-explosion-at-benin-city-filling-station/>. [Accessed: Oct. 21, 2024].
- [6] M. Kumar, G. Rattan, and R. Prasad, "Catalytic abatement of methane emission from CNG vehicles: an overview," *Canadian Chemical Transactions*, vol. 3, no. 4, pp. 381-409, 2015.
- [7] M. Schwartz, *ESP8266 Internet of Things Cookbook*. Birmingham, U.K.: Packt Publishing Ltd., 2017.
- [8] R. K. Kodali and K. S. Mahesh, "Low cost ambient monitoring using ESP8266," in *2016 2nd International Conference on Contemporary Computing and Informatics (IC3I)*, 2016, pp. 779-782.
- [9] A. V. Zinkevich, "ESP8266 microcontroller application in wireless synchronization tasks," in *Proc. 2021 Int. Conf. Ind. Eng., Appl. Manuf. (ICIEAM)*, May 2021, pp. 670-674.
- [10] L. Syafa'ah, A. E. Minarno, F. D. S. Sumadi, and D. A. P. Rahayu, "ESP 8266 for control and monitoring in smart home application," in *2019 International Conference on Computer Science, Information Technology, and Electrical Engineering (ICOMITEE)*, 2019, pp. 123-128.
- [11] M. A. Rahma, M. S. Muntini, and I. Sugriwan, "Methane (CH₄) detection system using the TGS2611 sensor and MQ-4 sensor," in *Journal of Physics: Conference Series*, vol. 2780, no. 1, p. 012034, Jun. 2024.
- [12] D. A. H. Fakra, D. A. S. Andriatoavina, N. A. M. N. Razafindralambo, K. Abdallah Amarillis, and J. M. M. Andriamampianina, "A simple and low-cost integrative sensor system for methane and hydrogen measurement," *Sensors Int.*, vol. 1, p. 100032, 2020.
- [13] N. M. Sakayo, J. N. Mutuku, and J. M. Ngaruiya, "Design and calibration of a microcontroller based MQ-4 gas sensor for domestic cooking gas system," *Int. J. Appl. Phys.*, vol. 6, no. 2, pp. 31-40, 2019.
- [14] J. Kalunga, S. Tembo, and J. Phiri, "Incorporating environmental protection requirement in industrial IoT access control security using Arduino technology MQ2 and DHT11 sensor networks," *International Journal of Advanced Science and Research Engineering*, vol. 8, no. 10, 2022.
- [15] M. M. H. Shuvo and S. Chowdhury, "IoT based fire detector system using MQ-4 and LM35 sensor," in *Proc. 2024 2nd Int. Conf. Sustainable Computing Smart Systems (ICSCSS)*, Jul. 2024, pp. 400-403.
- [16] I. K. Wardani, A. N. Ichniarsyah, M. Telaumbanua, B. Priyonggo, R. Fil'aini, Z. Mufidah, and D. A. Dewangga, "The feasibility study: Accuracy and precision of DHT 22 in measuring the temperature and humidity in the greenhouse," in *IOP Conference Series: Earth and Environmental Science*, vol. 1230, no. 1, p. 012146, Sep. 2023.
- [17] D. Yulizar, S. Soekirno, N. Ananda, M. A. Prabowo, I. F. Perdana, and D. Aofany, "Performance analysis comparison of DHT11, DHT22 and DS18B20 as temperature measurement," in *International Conference on Science Education and Sciences 2022 (ICSSES 2022)*, Aug. 2023.
- [18] A. H. Saptadi, "Comparison of temperature and humidity measurement accuracy between DHT11 and DHT22 sensors," *Jurnal Infotel*, vol. 6, no. 2, pp. 49-56, 2014.
- [19] M. M. Hassain, M. U. Apple, A. Mim, B. Das, and M. R. Mahmud, "GSM based system for vehicle gas leakage detection and driver condition assessment," in *Proc. 2024 Int. Conf. Adv. Electr. Commun. Technol. (ICAECOT)*, Oct. 2024, pp. 1-6.
- [20] R. Tschirschwitz, D. Krentel, M. Kluge, E. Askar, K. Habib, H. Kohlhoff, and M. Szczepaniak, "Hazards from failure of CNG automotive cylinders in fire," *J. Hazard. Mater.*, vol. 367, pp. 1-7, 2019.
- [21] R. Kumar, "Gas leakage monitoring & alerting sensor," Ph.D. dissertation, Jain Univ., Jharkland, 2019.